

## Double Loop Couplings with Stainless Steel Hubs (Flex P)

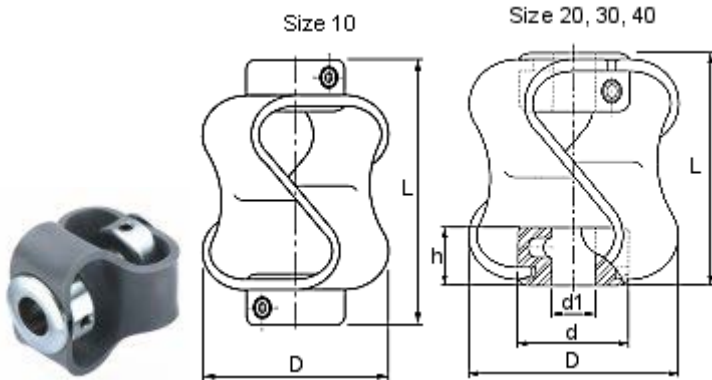

Max rotational speed: 3000 rpm

### Dimensions and Order Codes

Coupling Size	Coupling Ref	Max Dia.	Max Bore	Length L	Hub Height h	Fastener			Mass
		D	d1			Size	Torque	Wrench	
		mm	mm	mm	mm		Nm	mm	kg x 10 <sup>-3</sup>
10	049.10	27	9.53	27	7.9	M3	0.32	1.5	25
20	049.20	48	12.7	48	12.7	M4	2	2	92
30	049.30	54	16	55	16	M5	2.1	2.5	124
40	049.40	56	16	56	16	M6	3.75	3	136

### Materials & Finishes

#### Hubs:

Stainless steel 303 S31 and Steel 230M07 pb Zn plated + clear passivate

#### Double loop element:

HYRTEL®.

Temperature Range: -40°C to +100°C

### Performance

Coupling Size	Coupling Ref	Max Torque (1)	Max Torque (2)	Maximum misalignment/displacement		
				Angular	Radial	Axial
		Nm	Nm	deg	mm	mm
10	049.10	0.5	0.8	10	2.6	4.5
20	049.20	1.8	3	15	3.2	7.5
30	049.30	5	8	15	3.2	8.5
40	049.40	10	18	15	3.2	11

#### Table Notes:

1. Maximum torque at maximum displacement.
2. Maximum torque at displacement 1° angular, 2mm axial, 0.5mm radial.